



CONSTRUCTION PRODUCT TECHNICAL CARD

Product feature: Flowmeter included	Energeo product: SPIDER – R Distributor well with multi-sectional manifolds	 Sgn:EN.OZE.20-13.SP
Manufacturer: ASPOL-FV Łódź, ul. Helska 39/45 www.aspol.com.pl		
ENERGEO – GEOTHERMAL TECHNOLOGY FOR GROUND SOURCE HEAT PUMPS – RENEWABLE ENERGY SOURCES		

Legally protected brand according to the decision of the Polish Republic Patent Office

EN.OZE.20-13.SP

Uniform text dated 08. October 2013

1. List of standards / legislation and other documents related to the product:

- PN-EN 10226-1:2006;
- PN-EN ISO 228-1:2005 PN-EN ISO 228-2:2005
- PN-EN 12201-1:2012, PN-EN 12201-2:2012, PN-EN 12201-3:2012, PN-EN 12201-4:2013;
- PN-EN 805:2002; PN-EN 805:2002/Ap1:2006;
- PN-EN ISO 1167-1:2007, PN-EN ISO 1167-2:2007, PN-EN ISO 1167-3:2008, PN-EN ISO 1167-4:2008;
- PN-EN 1074-5:2002;
- PN-EN 1267:2012;
- PN-ISO 9624:2001;
- PN-ISO 9623:2001;
- PN-B-02481:1998;
- PN-C-88012:1999;
- PN-C-88013-3:1999;
- VDI 4640;
- DIN 8075:1999;
- EN.OZE-PS:20-14.01; Distributor well assembly guidelines;
- EN.OZE-WW:20-12.1; Ground source for heat pumps assembly guidelines.

2. SPIDER-R – distributor well – a component of the Energeo* system

The New SPIDER-R distributor well is an element of ground source system for heat pumps. It consists of a *manifold* (collector) in-built into a plastic chamber (*well*). SPIDER-R is a well manhole (allows maintenance operations).

2.1 Manifold – an element of the hydraulic system consisting of two cylindrical collector bars with radial collector (SK) flow sections. Material: HDPE-100/HDPE- 100RC.

Manifold flow line – flowmeter with flow guard is mounted on each antifreeze circuit in order to provide proper hydraulic balance and adjustment. Every circuit is controlled, with the option of cutting-off (closing).

Manifold return line – cut-off ball valve for each antifreeze circuit.

The manifold main functions are as follows:

- Divide antifreeze liquid flowing from the heat pump through the manifold return line to the underground heat exchanger and transfer it back through the manifold flow line to the heat pump;
- Ensure hydraulic control, filling-up, cutting-off and venting.

Outlet section with nickel plated brass internal thread socket for air vent valve is equipped with cut-off valve as standard Collector pipes (SK) and connection pipes (RD) are intended for both: electro-fusion and socket-welding techniques. Leak tightness is guaranteed by polyfusion welding method.

* ENERGEO is a balanced hydraulic system developed to transfer geothermal energy from the ground, watercourses and water areas to the heat pump which provides energy for heating, cooling and hot water for dwellings, residential buildings and commercial facilities

3. Technical parameters of the SPIDER-R distribution well:

PARAMETER	SPIDER - R
Number of sections (SK)	15-25 [pairs]
Material of chamber/manifold	HDPE/HDPE
Chamber wall thickness	≥8 mm
Manifold pressure class	PN16
Standard collector pipe diameter (SK)	32, 40 [mm]
SK pipe welding method	Polyfusion
Standard connection tube diameter (RD)	63,75,90,110,125 [mm]
RD pipe welding method	Polyfusion
Diameter of manifold main supply	400 [mm]
Internal thread socket for air vent valve	1/2"
Internal thread socket for filling	3/4"
A flowmeters range	2÷12 [dm ³ /min]
B flowmeters range	8÷38[dm ³ /min]
C flowmeters range	20÷70 [dm ³ /min]
Angle flowmeters range	5÷50 [dm ³ /min]
Dimensions: Height/diameter	1640/1000 [mm]
Maximum foundation depth	2140 [mm]

3.1. The SPIDER weight, pressure losses and capacity:

Sections	SPIDER Weight	Capacity	Antifreeze liquid			
			Manifold pressure drop for a flow of 0.5 m ³ /h per section		Manifold pressure drop for a flow of 1.5 m ³ /h per section	
			Ethylene glycol water solution 20E15 (-15°C)	Propylene glycol water solution 20P15 (-15°C)	Ethylene glycol water solution 20E15 (-15°C)	Propylene glycol water solution 20P15 (-15°C)
-	[kg]	[dm ³]	[kPa]	[kPa]	[kPa]	[kPa]
15	162	50,6	2,16	2,26	19,27	19,72
16	164	50,9	2,18	2,29	19,54	19,98
17	165	51,2	2,22	2,32	19,83	20,28
18	167	51,5	2,25	2,35	20,13	20,58
19	169	51,9	2,29	2,39	20,45	20,90
20	172	52,2	2,32	2,42	20,78	21,24
21	174	52,5	2,37	2,47	21,14	21,59
22	176	52,8	2,41	2,51	21,50	21,96
23	178	53,1	2,45	2,55	21,90	22,35
24	180	53,5	2,50	2,60	22,30	22,75
25	182	53,8	2,55	2,64	22,71	23,17

Approximate values. Calculation condition: Operating temperature: 0°C, Linear Flowmeter, RD- diameter: 110 mm, length: 50 cm, SK- diameter: 32 mm, length 40 cm.

4. Load-capacity, thermal insulation, foundation depth

The depth of wells Spider is 1640 mm. Each distributor well is equipped with a HDPE cover

(load capacity of 10 kN). The cover may be additionally equipped with a closing mechanism and/ or thermal insulation.

If it is required that the distribution well carry larger loads, it can be additionally equipped with:

- Polyester manhole cover with a conical load ring made of resin-cement. Load capacity up to 125 kN;
- Cast iron manhole, class D400, with loading concrete plate to carry loads up to 400 kN.

NOTE! The well capping method used should be based on a technical and construction design that takes into consideration all relevant water and ground conditions, the well's size and expected loads in accordance with the following standards: PN-EN 1991-2:2007 and PN-EN 1990:2004.

5. Equivalent products – see technical card

- ALTRA Divider well in terms of 14 section EN.OZE.20-13.AL;
- SPIDER MAXI Divider well in terms of 20-25 section EN.OZE.20-13.SPM;
- Wall divider type RS, full range in accordance with EN.OZE.20-13;RS.

6. Information Technology

- The SPIDER-R is available in the "ENERGEO SOFT" computer program (design/selection of ground sources for heat pumps).
- The SPIDER-R is designed to be compatible with Electronic Diagnostic System for GSHP (EDS) to facilitate electronic diagnostics and archiving of working parameters of ground source in accordance with EN.EDS.20-13;01

7. Supplementary components

- Connection pipes (in accordance with EN.OZE.20-13;RD);
- Distribution pipes (in accordance with EN.OZE.20-13;RR);
- Vertical/horizontal exchangers (in accordance with EN.OZE.20-13;WG);
- Pipeway through wall barriers (in accordance with EN.OZE.20-13;PB);
- Heat pump engine room equipment;
- Antifreeze liquids: glycols and glycol water solutions (in accordance with EN.OZE.20-13;GH);
- Marking accessories;

8. Classification, training, qualifications and certification

Qualifications to install the system of ground source heat pumps, including the SPIDER-R well, should be gained through participation in training courses organized by the producer or by training institutions authorised by them.

9. The product is characterised by the following features:

- Material uniformity for all plastic hydraulic elements: HDPE-100/HDPE-100RC
- Transitions section of the collector through the wall of the chamber (well), which is the case are made by polyfusion welding method;
- All plastic connections base on polyfusion welding method
- It has a manhole structure equipped with stairs permitting inspection service operations;
- It is equipped with a cylindrical divider consists of two separate chambers: the supply and return of the collector sections derived;
- Collector sections (inflow and return) are grouped in pairs (don't cross);
- Easy accesses to vents and filling up;
- A regular system of training courses available to ensure professional installation;
- IT design tools available to enable correct selection and product configuration for any system of ground sources;
- Certified technical service is provided.

10. 15-section distribution well: SPIDER-R flowmeters included– technical drawings*.

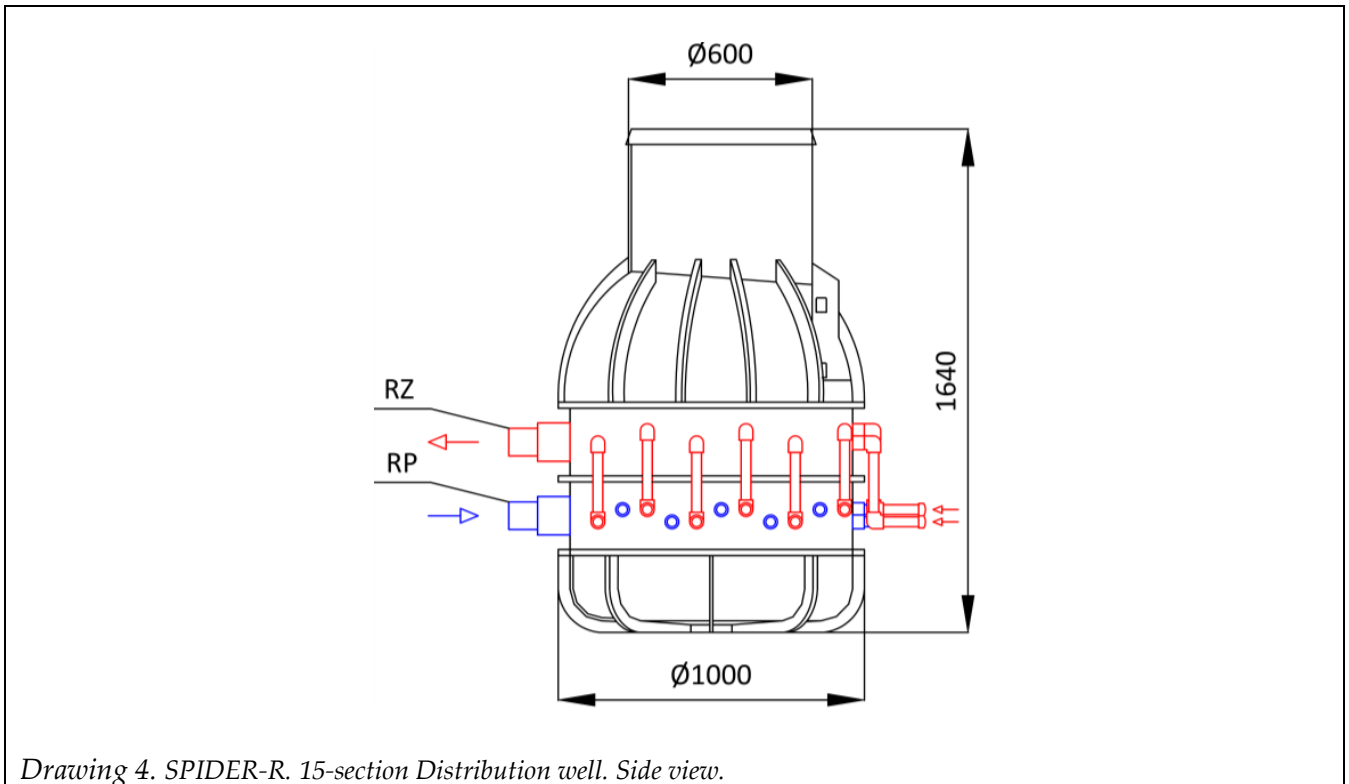

Drawing 4. SPIDER-R. 15-section Distribution well. Side view.

SK – Collector Pipes, **RZ** – Supply Connection Tube, **RP** – Return Connection Tube, **R** – Flowmeter, **ZO** – Cut Off Valve, **OZ**- Straight Valve with coupler 1/2" internal thread for Air Vent supply section, **NZ**- Straight Valve with coupler 3/4 " internal thread for Filling Up supply section, **OP**- Straight Valve with coupler 1/2" internal thread for Air Vent return section, **NP**- Straight Valve with coupler 3/4 " internal thread for Filling Up return section, **ZKL** – Butterfly Valves.

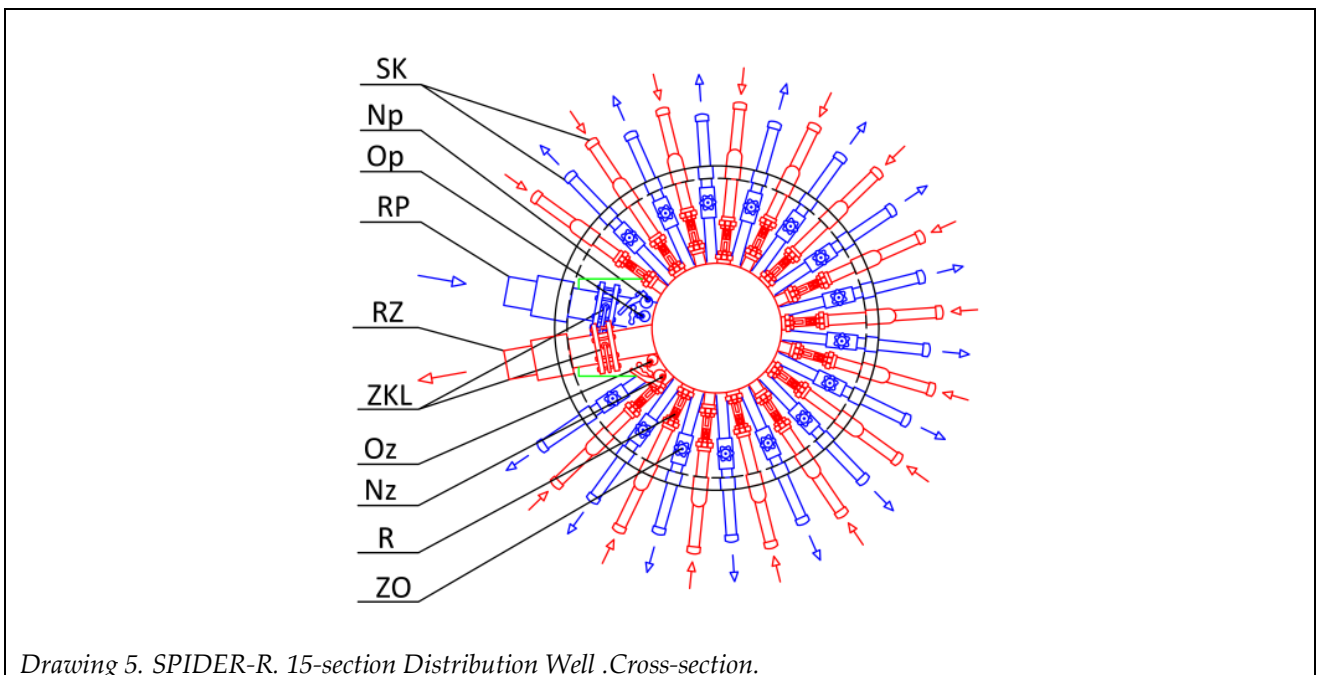

Drawing 5. SPIDER-R. 15-section Distribution Well .Cross-section.

*

Changes in technical solutions may cause differences between the drawings and the product

11. 16-section distribution well: SPIDER-R flowmeters included– technical drawings*.

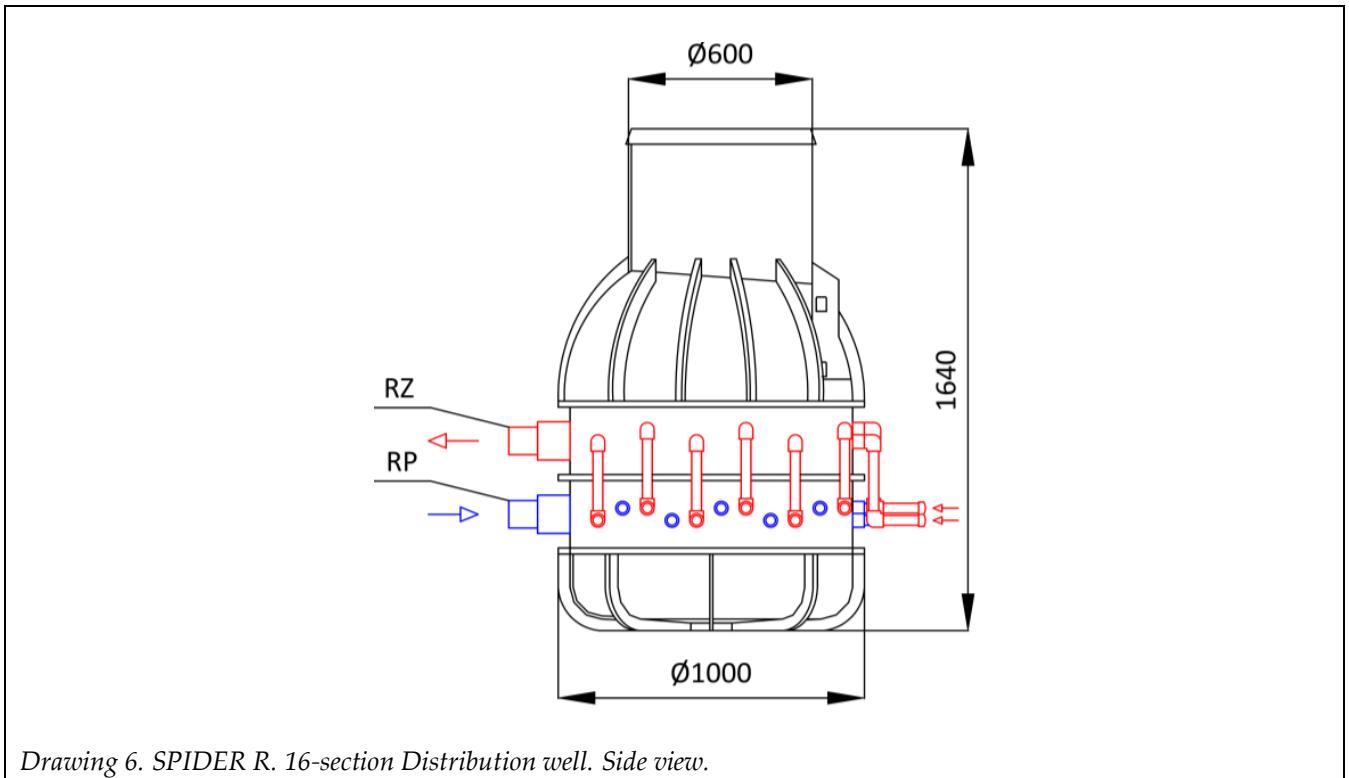

Drawing 6. SPIDER R. 16-section Distribution well. Side view.

SK – Collector Pipes, **RZ** – Supply Connection Tube, **RP** – Return Connection Tube, **R** – Flowmeter, **ZO** – Cut Off Valve, **OZ**- Straight Valve with coupler 1/2" internal thread for Air Vent supply section, **NZ**- Straight Valve with coupler 3/4" internal thread for Filling Up supply section, **OP**- Straight Valve with coupler 1/2" internal thread for Air Vent return section, **NP**- Straight Valve with coupler 3/4" internal thread for Filling Up return section, **ZKL** – Butterfly Valves.

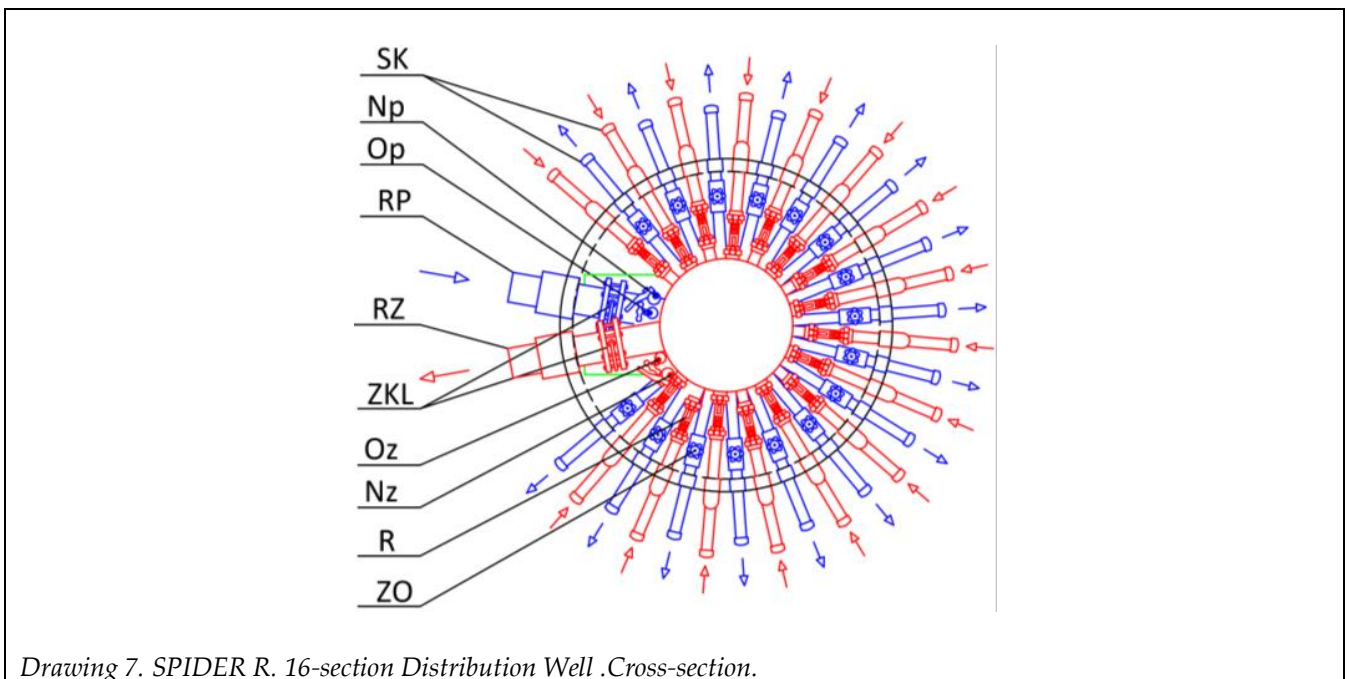

Drawing 7. SPIDER R. 16-section Distribution Well. Cross-section.

* Changes in technical solutions may cause differences between the drawings and the product

12. 17-section distribution well: SPIDER-R flowmeters included– technical drawings*.

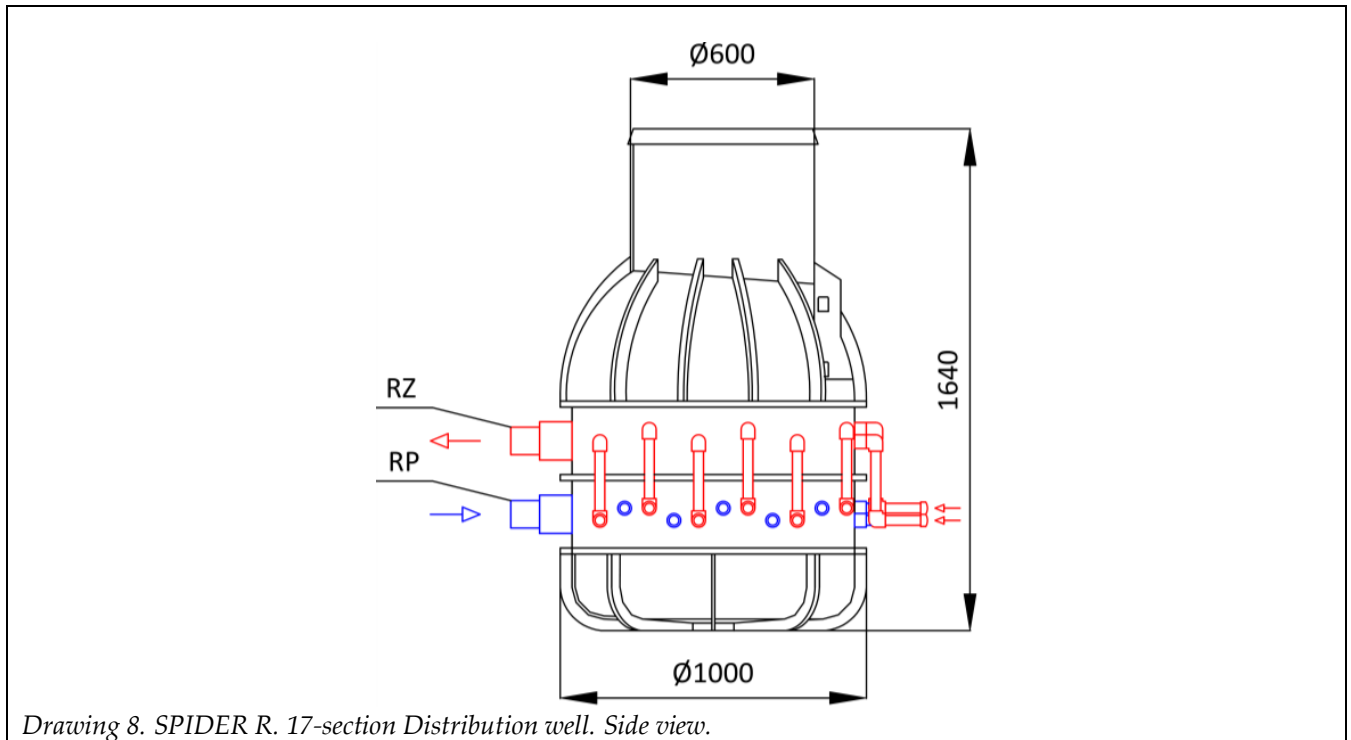

SK – Collector Pipes, **RZ** – Supply Connection Tube, **RP** – Return Connection Tube, **R** – Flowmeter, **ZO** – Cut Off Valve, **OZ**- Straight Valve with coupler ½" internal thread for Air Vent supply section, **NZ**- Straight Valve with coupler ¾" internal thread for Filling Up supply section, **OP**- Straight Valve with coupler ½" internal thread for Air Vent return section, **NP**- Straight Valve with coupler ¾" internal thread for Filling Up return section, **ZKL** – Butterfly Valves.

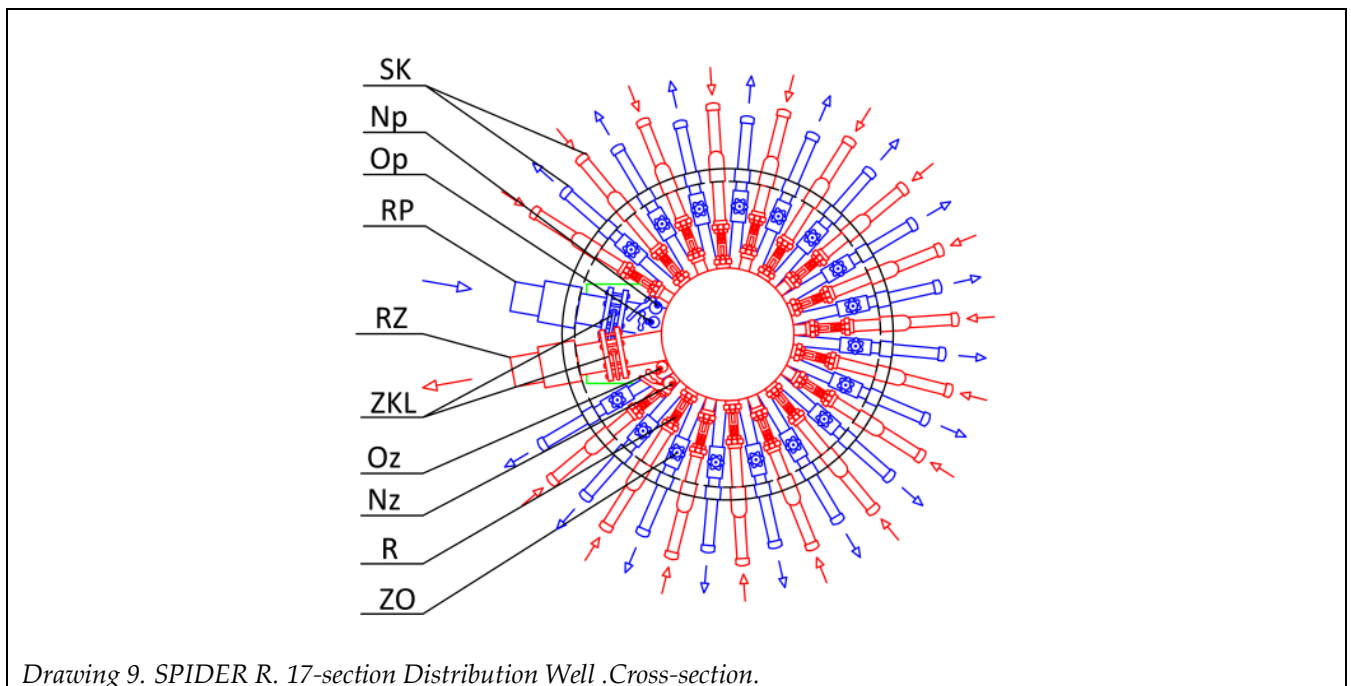

* Changes in technical solutions may cause differences between the drawings and the product



13. 18-section distribution well: SPIDER-R flowmeters included– technical drawings*.

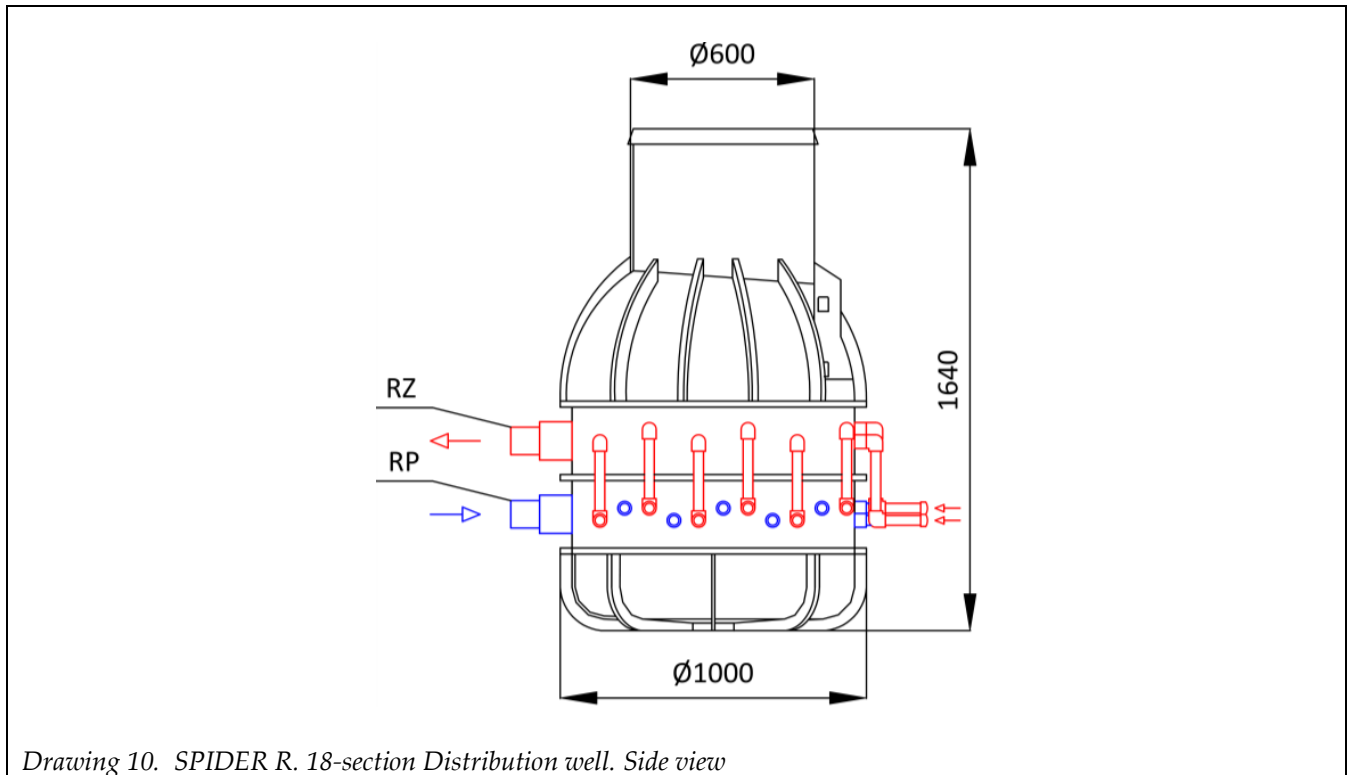

Drawing 10. SPIDER R. 18-section Distribution well. Side view

SK – Collector Pipes, **RZ** – Supply Connection Tube, **RP** – Return Connection Tube, **R** – Flowmeter, **ZO** – Cut Off Valve, **OZ**- Straight Valve with coupler ½" internal thread for Air Vent supply section, **NZ**- Straight Valve with coupler ¾" internal thread for Filling Up supply section, **OP**- Straight Valve with coupler ½" internal thread for Air Vent return section, **NP**- Straight Valve with coupler ¾" internal thread for Filling Up return section, **ZKL** – Butterfly Valves.

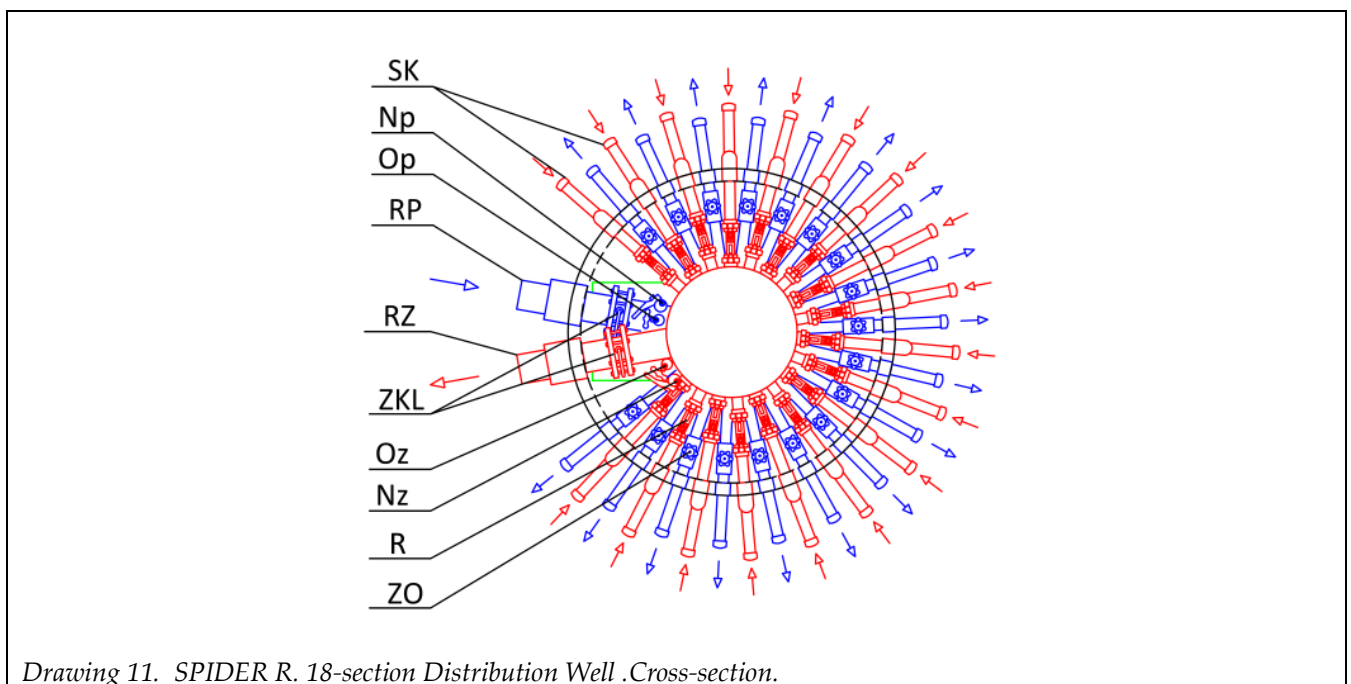

Drawing 11. SPIDER R. 18-section Distribution Well. Cross-section.

* Changes in technical solutions may cause differences between the drawings and the product

14. 19-section distribution well: SPIDER-R flowmeters included– technical drawings*.

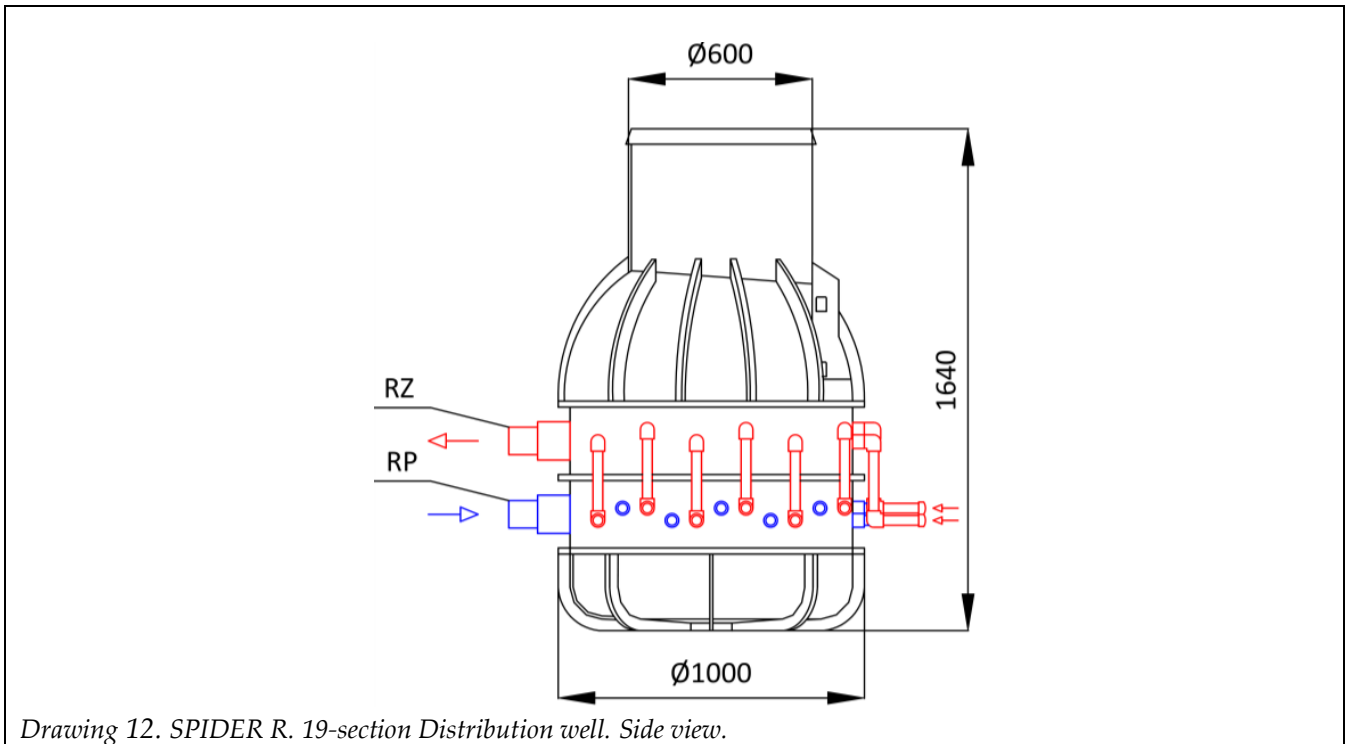

Drawing 12. SPIDER R. 19-section Distribution well. Side view.

SK – Collector Pipes, **RZ** – Supply Connection Tube, **RP** – Return Connection Tube, **R** – Flowmeter, **ZO** – Cut Off Valve, **OZ**- Straight Valve with coupler ½" internal thread for Air Vent supply section, **NZ**- Straight Valve with coupler ¾" internal thread for Filling Up supply section, **OP**- Straight Valve with coupler ½" internal thread for Air Vent return section, **NP**- Straight Valve with coupler ¾" internal thread for Filling Up return section, **ZKL** – Butterfly Valves.

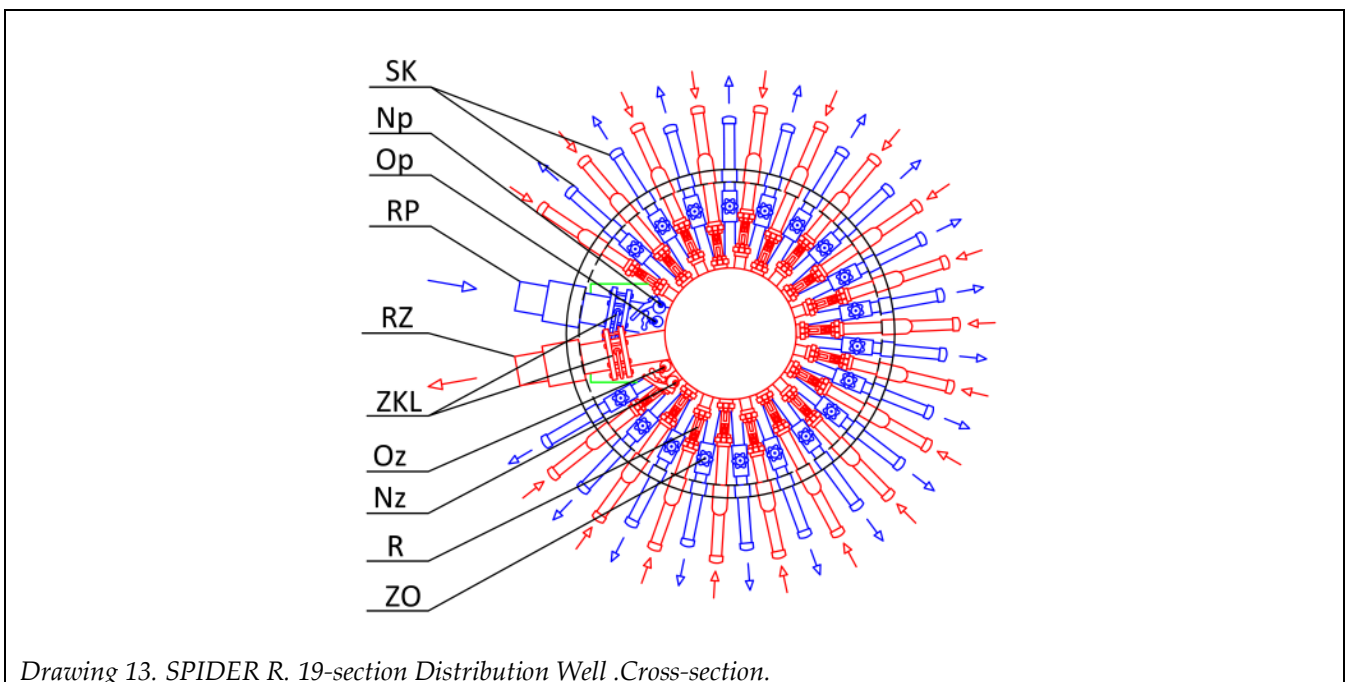

Drawing 13. SPIDER R. 19-section Distribution Well. Cross-section.

* Changes in technical solutions may cause differences between the drawings and the product

15. 20-section distribution well: SPIDER-R flowmeters included– technical drawings*.

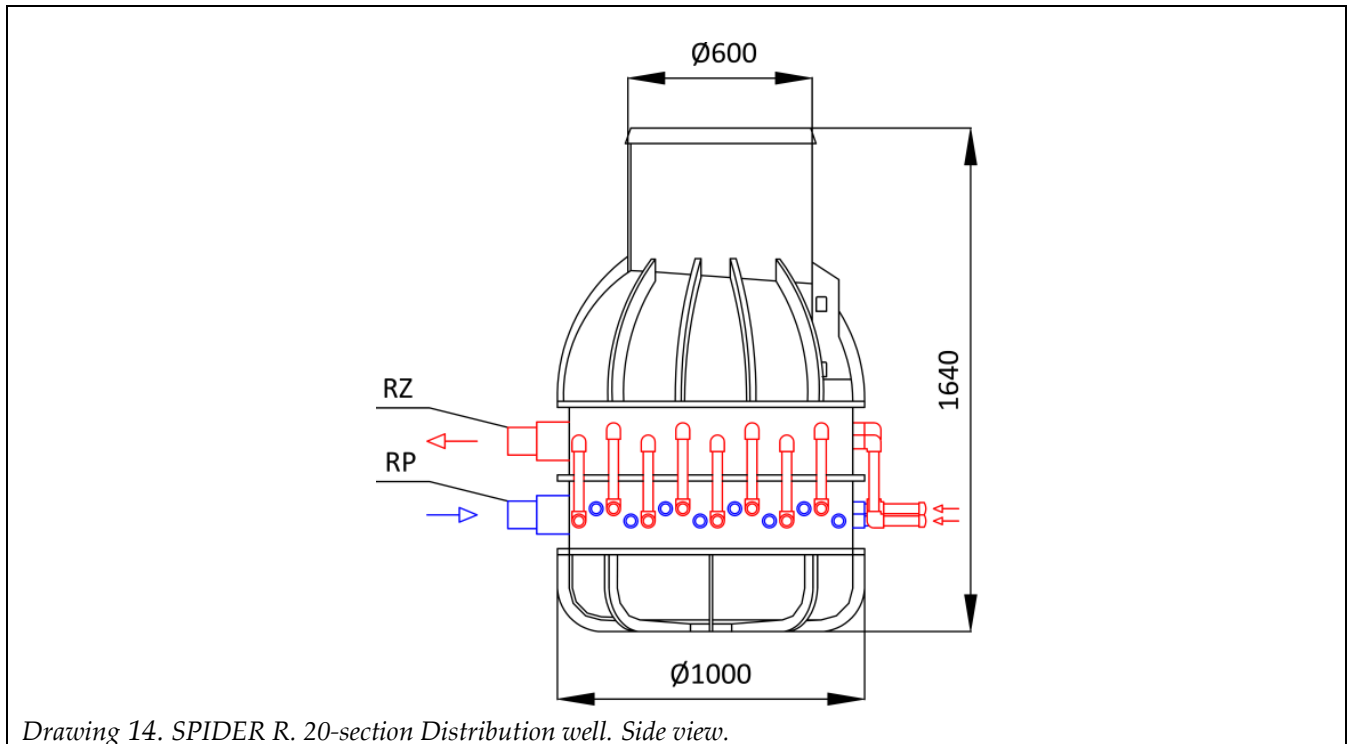

SK – Collector Pipes, RZ – Supply Connection Tube, RP – Return Connection Tube, R – Flowmeter, ZO – Cut Off Valve, OZ- Straight Valve with coupler 1/2" internal thread for Air Vent supply section, NZ- Straight Valve with coupler 3/4" internal thread for Filling Up supply section, OP- Straight Valve with coupler 1/2" internal thread for Air Vent return section, NP- Straight Valve with coupler 3/4" internal thread for Filling Up return section, ZKL – Butterfly Valves.

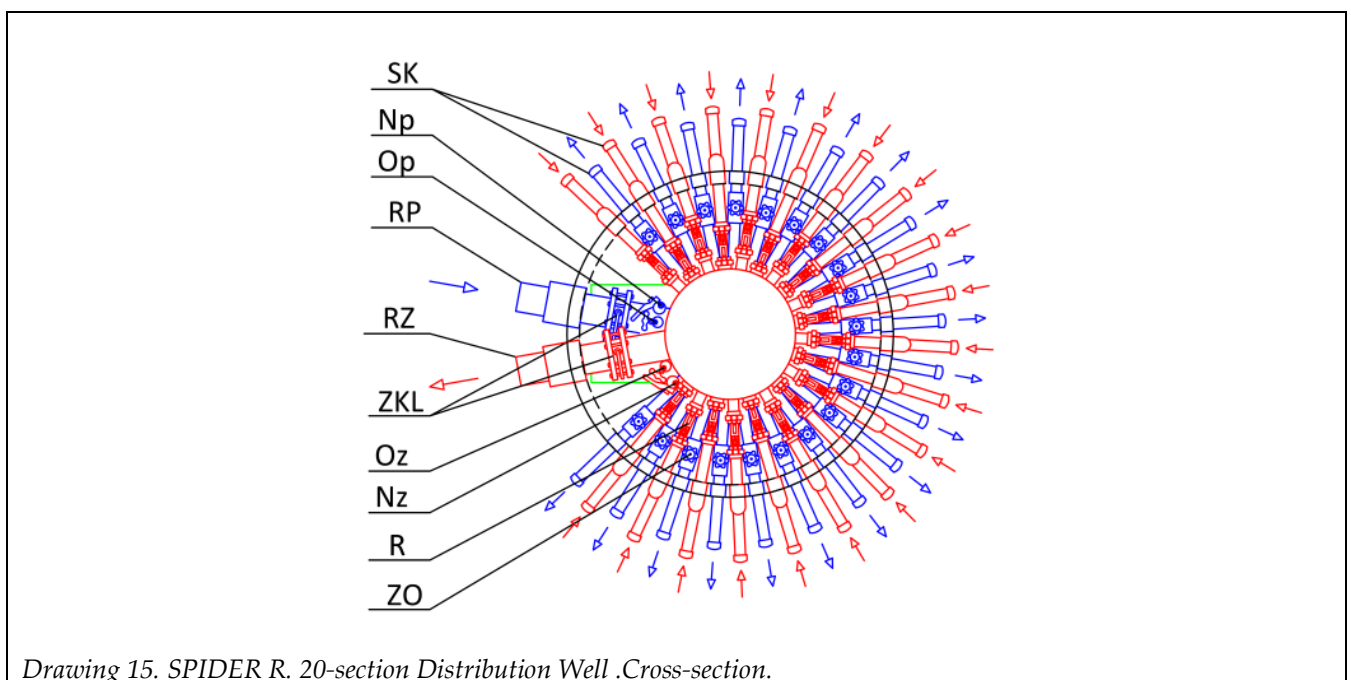

* Changes in technical solutions may cause differences between the drawings and the product

16. 21-section distribution well: SPIDER-R flowmeters included– technical drawings*.

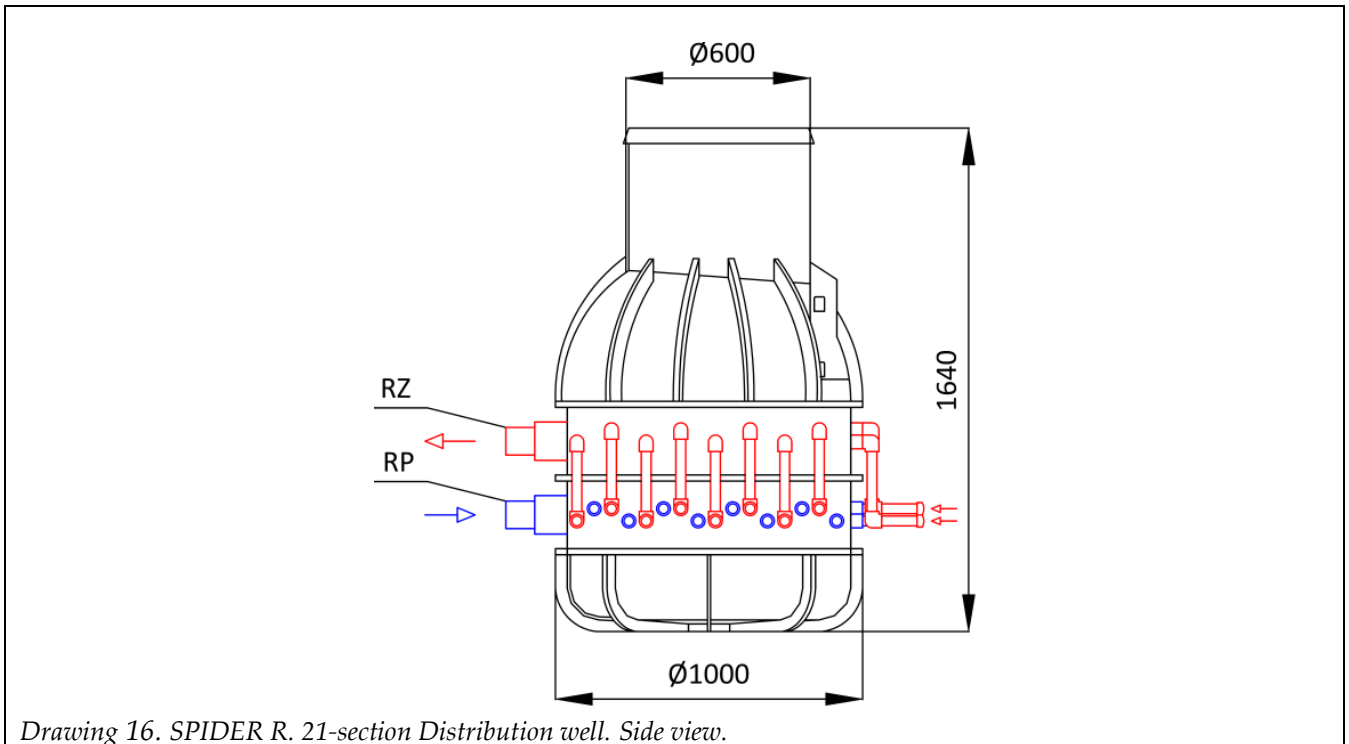

SK – Collector Pipes, **RZ** – Supply Connection Tube, **RP** – Return Connection Tube, **R** – Flowmeter, **ZO** – Cut Off Valve, **OZ**- Straight Valve with coupler ½" internal thread for Air Vent supply section, **NZ**- Straight Valve with coupler ¾" internal thread for Filling Up supply section, **OP**- Straight Valve with coupler ½" internal thread for Air Vent return section, **NP**- Straight Valve with coupler ¾" internal thread for Filling Up return section, **ZKL** – Butterfly Valves.

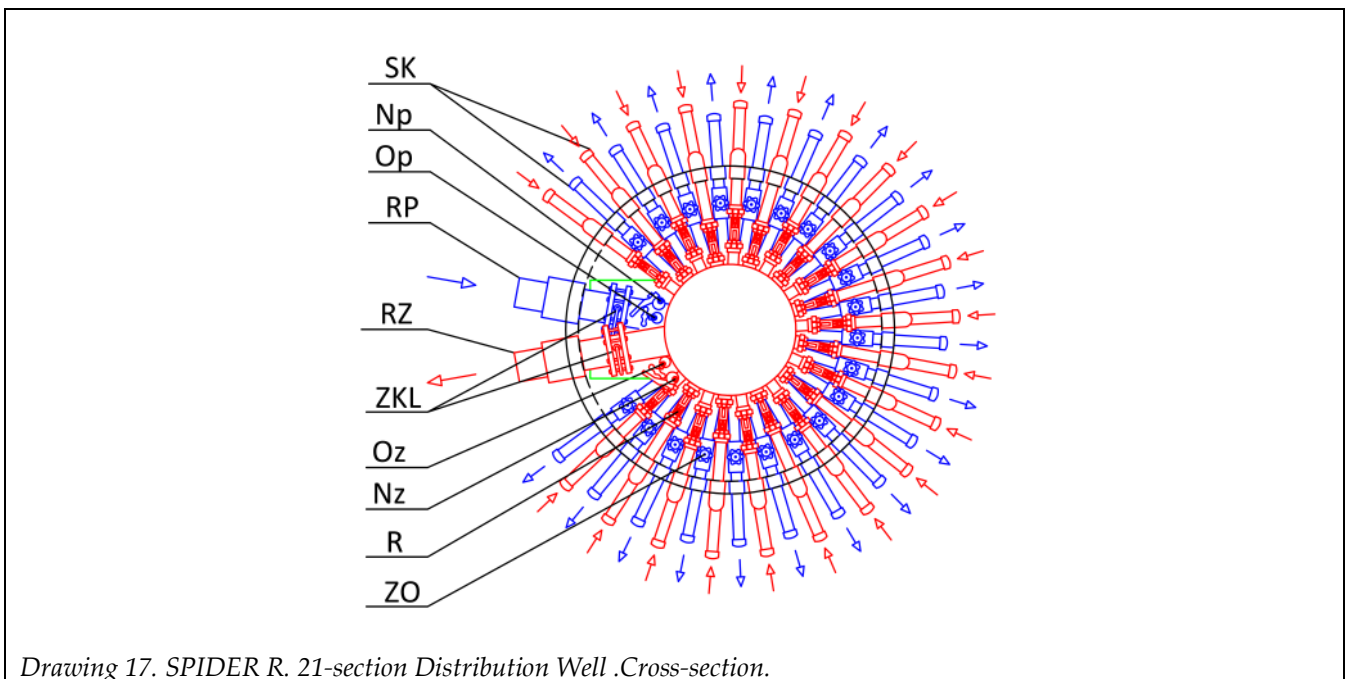

* Changes in technical solutions may cause differences between the drawings and the product

17. 22-section distribution well: SPIDER-R flowmeters included– technical drawings*.

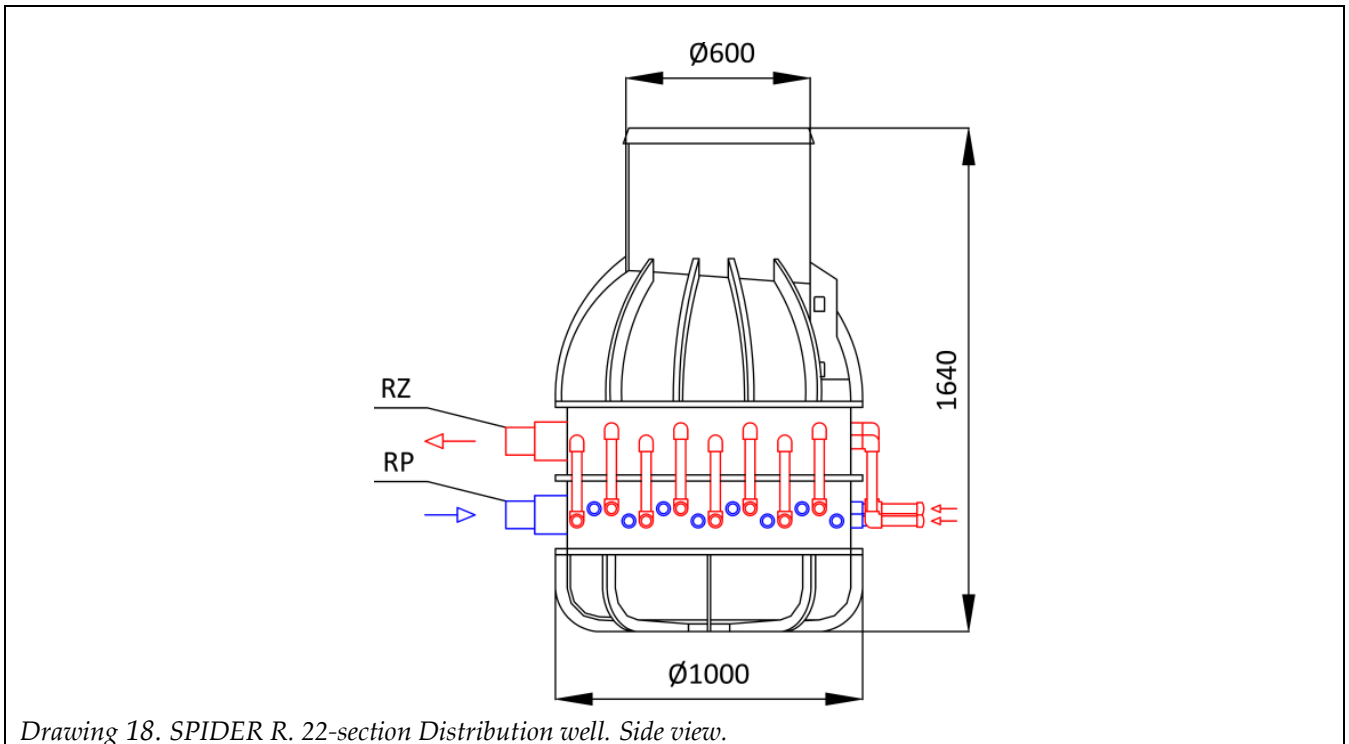

Drawing 18. SPIDER R. 22-section Distribution well. Side view.

SK – Collector Pipes, **RZ** – Supply Connection Tube, **RP** – Return Connection Tube, **R** – Flowmeter, **ZO** – Cut Off Valve, **OZ**- Straight Valve with coupler 1/2" internal thread for Air Vent supply section, **NZ**- Straight Valve with coupler 3/4 " internal thread for Filling Up supply section, **OP**- Straight Valve with coupler 1/2" internal thread for Air Vent return section, **NP**- Straight Valve with coupler 3/4 " internal thread for Filling Up return section, **ZKL** – Butterfly Valves. .

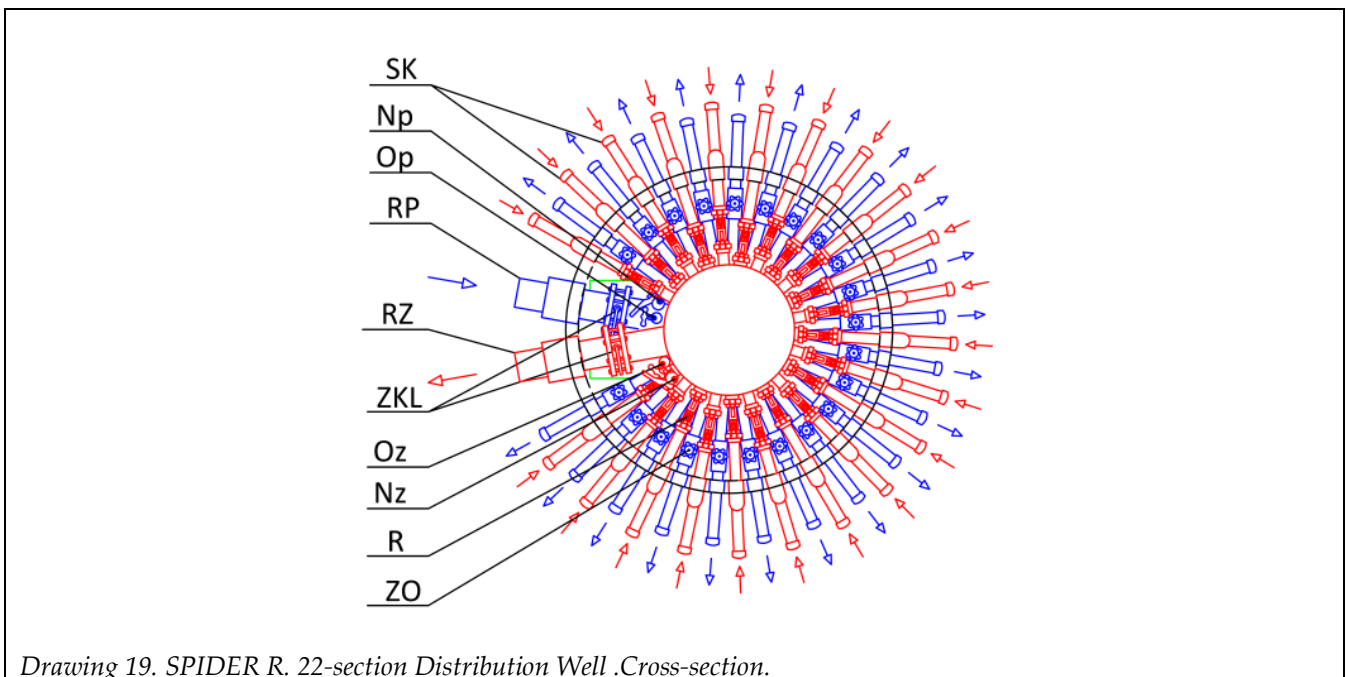

Drawing 19. SPIDER R. 22-section Distribution Well .Cross-section.

* Changes in technical solutions may cause differences between the drawings and the product



18. 23-section distribution well: SPIDER-R flowmeters included– technical drawings*.

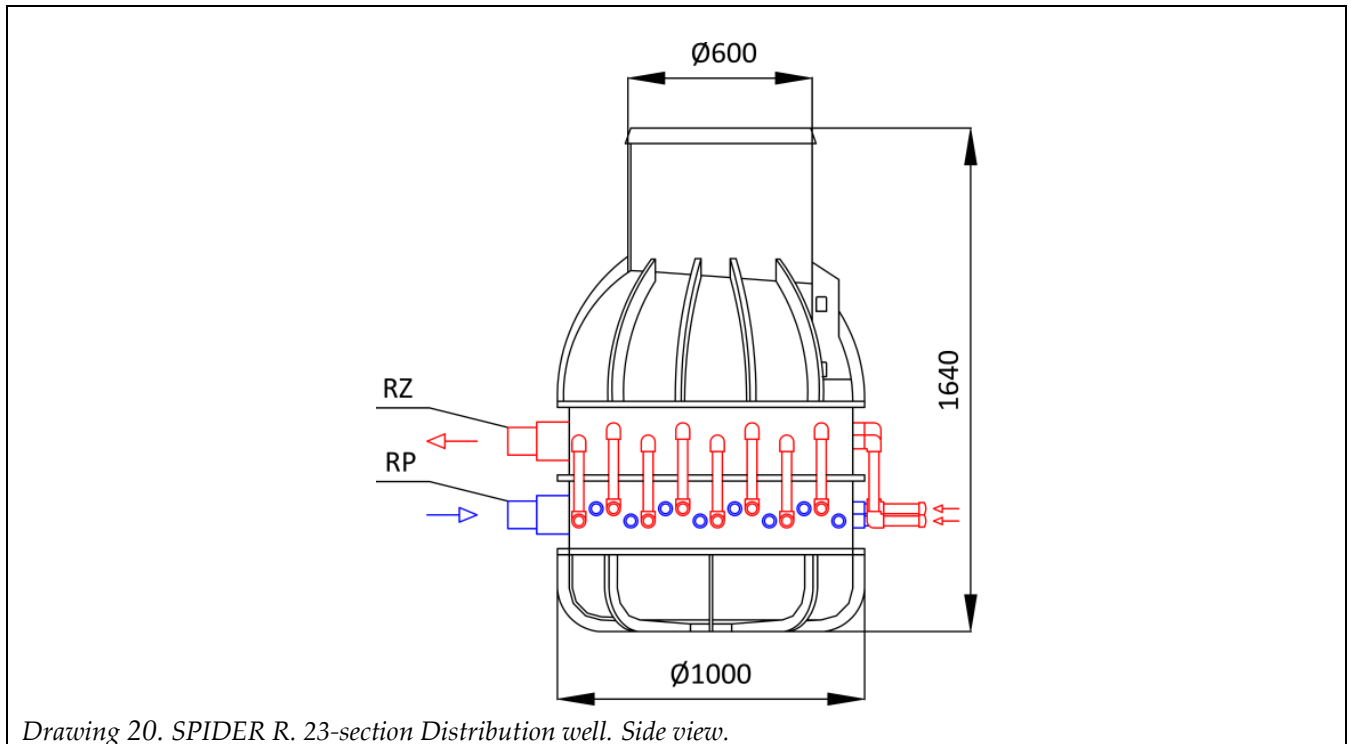

SK – Collector Pipes, **RZ** – Supply Connection Tube, **RP** – Return Connection Tube, **R** – Flowmeter, **ZO** – Cut Off Valve, **OZ**- Straight Valve with coupler ½" internal thread for Air Vent supply section, **NZ**- Straight Valve with coupler ¾" internal thread for Filling Up supply section, **OP**- Straight Valve with coupler ½" internal thread for Air Vent return section, **NP**- Straight Valve with coupler ¾" internal thread for Filling Up return section, **ZKL** – Butterfly Valves.

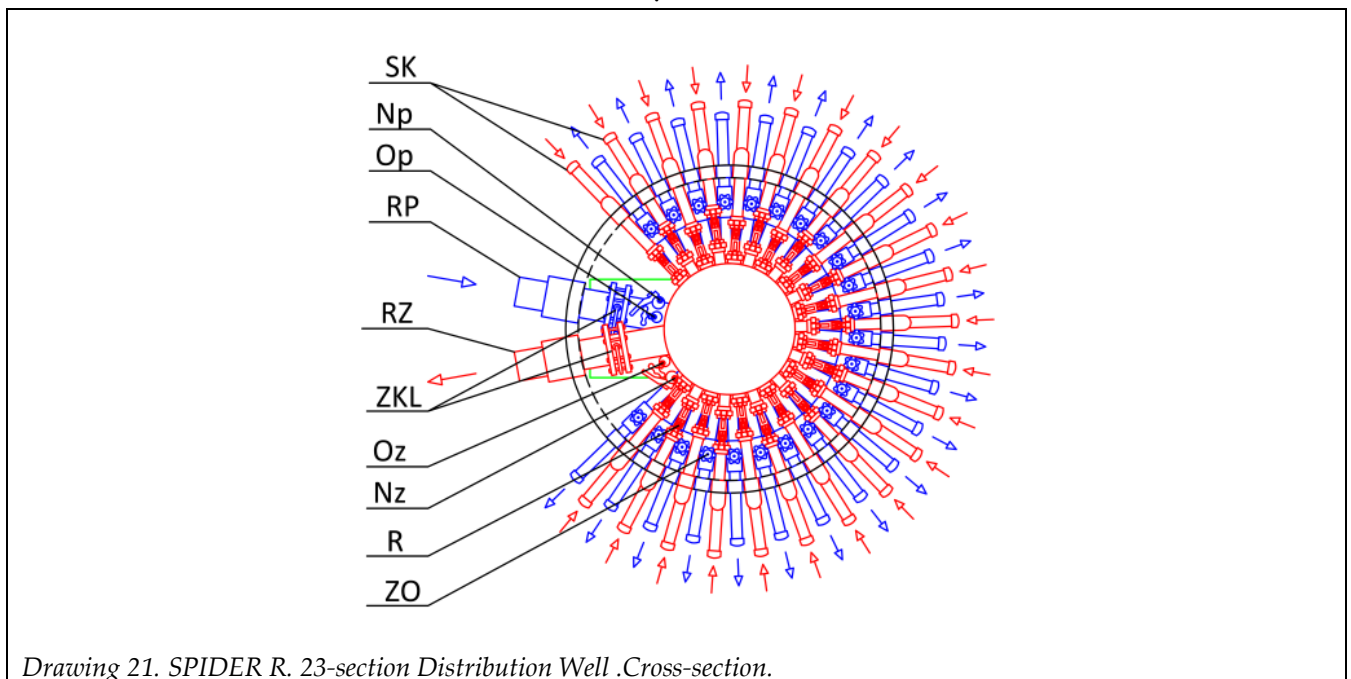

* Changes in technical solutions may cause differences between the drawings and the product

19. 24-section distribution well: SPIDER-R flowmeters included– technical drawings*.

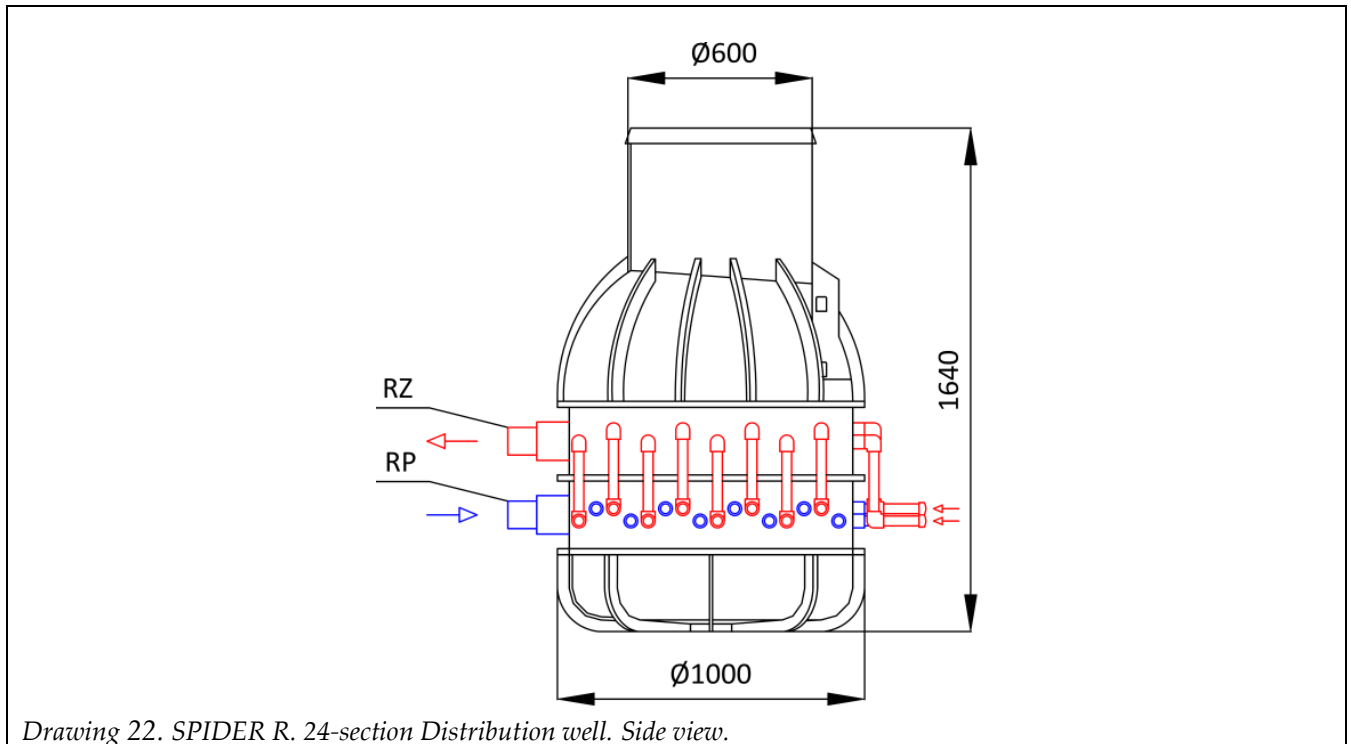

SK – Collector Pipes, **RZ** – Supply Connection Tube, **RP** – Return Connection Tube, **R** – Flowmeter, **ZO** – Cut Off Valve, **OZ**- Straight Valve with coupler 1/2" internal thread for Air Vent supply section, **NZ**- Straight Valve with coupler 3/4 " internal thread for Filling Up supply section, **OP**- Straight Valve with coupler 1/2" internal thread for Air Vent return section, **NP**- Straight Valve with coupler 3/4 " internal thread for Filling Up return section, **ZKL** – Butterfly Valves.

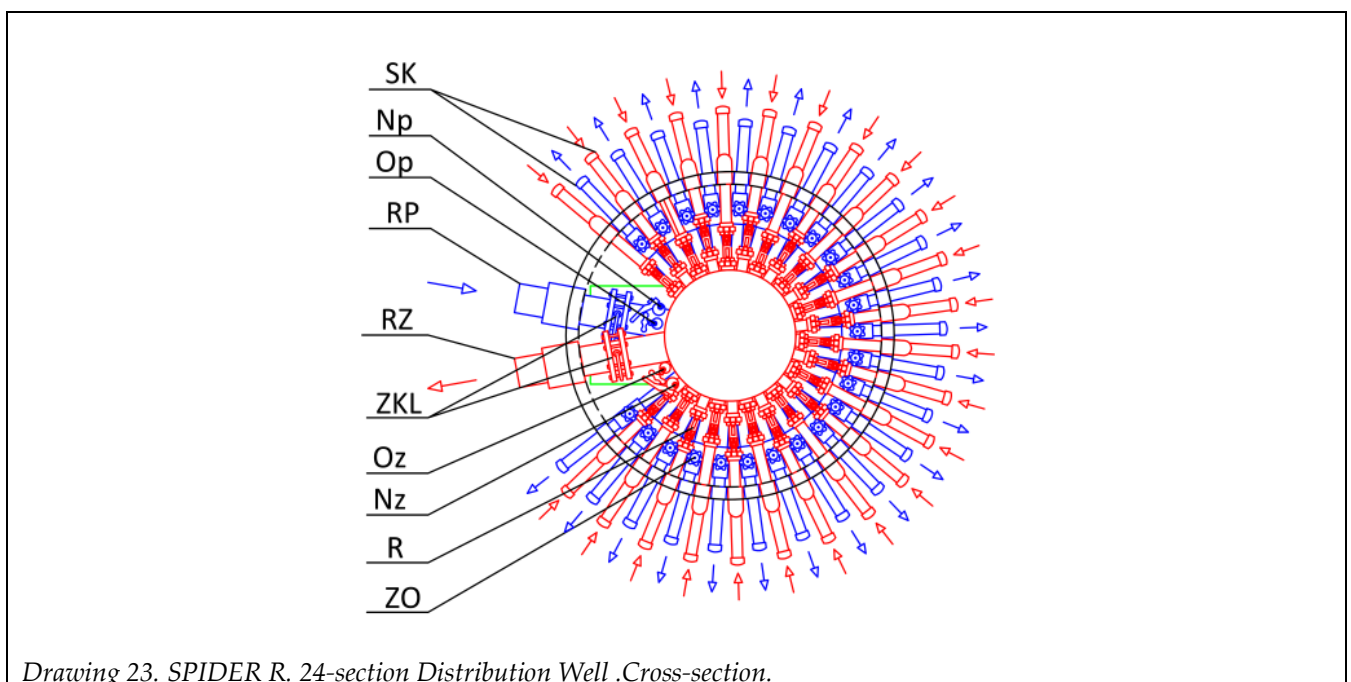

* Changes in technical solutions may cause differences between the drawings and the product

20. 25-section distribution well: SPIDER-R flowmeters included– technical drawings*.

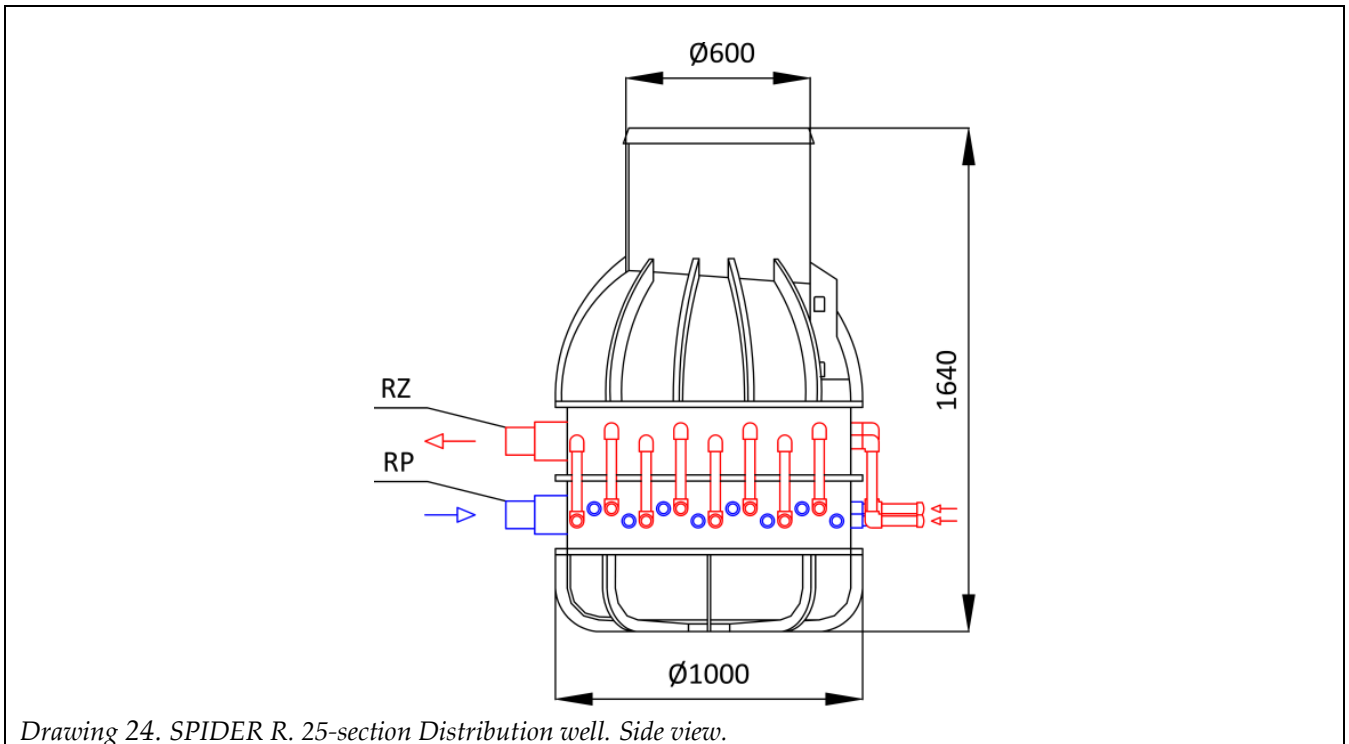

Drawing 24. SPIDER R. 25-section Distribution well. Side view.

SK – Collector Pipes, **RZ** – Supply Connection Tube, **RP** – Return Connection Tube, **R** – Flowmeter, **ZO** – Cut Off Valve, **OZ**- Straight Valve with coupler 1/2" internal thread for Air Vent supply section, **NZ**- Straight Valve with coupler 3/4 " internal thread for Filling Up supply section, **OP**- Straight Valve with coupler 1/2" internal thread for Air Vent return section, **NP**- Straight Valve with coupler 3/4 " internal thread for Filling Up return section, **ZKL** – Butterfly Valves.

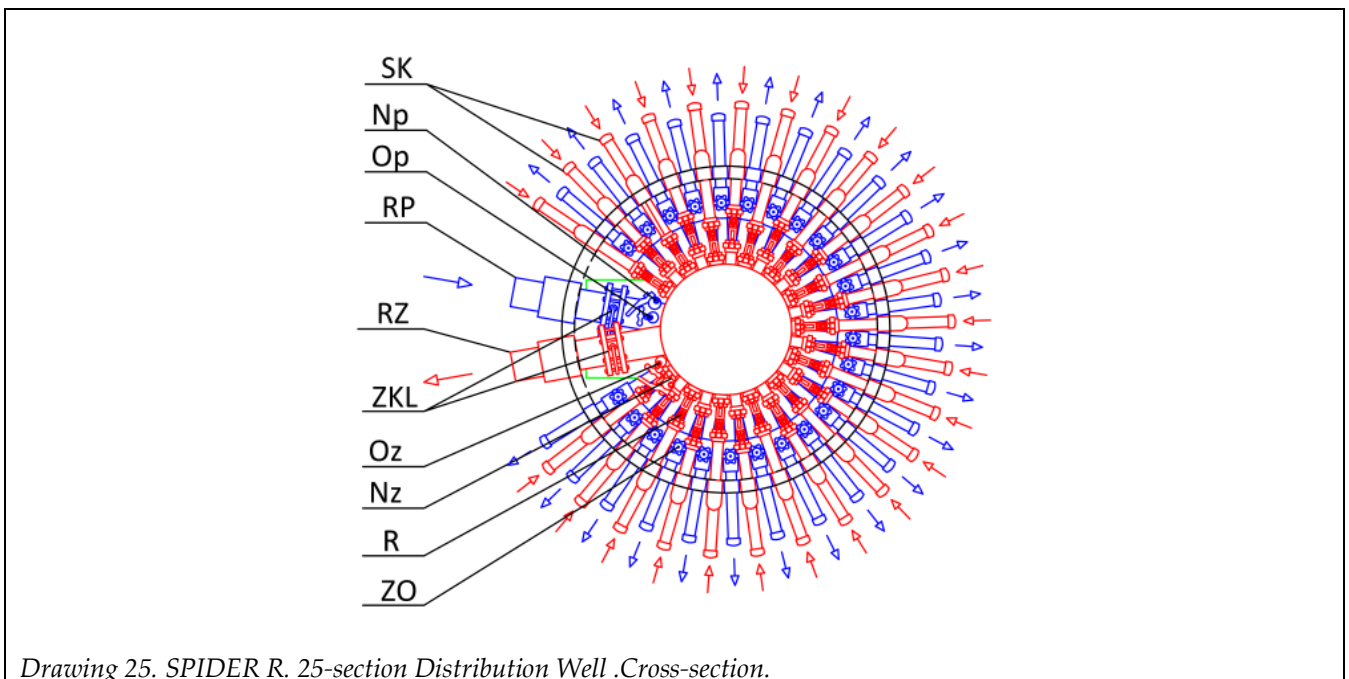

Drawing 25. SPIDER R. 25-section Distribution Well .Cross-section.

* Changes in technical solutions may cause differences between the drawings and the product